

SAMPLE — NOT FOR INSTALLATION

Demonstrative document showing the format and depth of every paid Permit-Ready Report. Generate yours for your specific project: powerlab.marinepowerlab.com/features/permit-ready (\$59 CAD).

Permit-Ready Electrical Report

Marine DC + AC System Design

Sample 32 ft Sailboat — DC + AC Demo

Owner / Applicant: Sample Owner (demonstration)

Installation type: Sailboat — Vancouver Harbour, BC (sample location)

System: 12 V DC + 120 V single-phase

Applicable code: Marine — ABYC E-11 (AC & DC Electrical Systems on Boats)

Generated: 2026-06-01, 10:49 p.m. PDT

This report is an engineering-input document prepared by PowerLab. It is not a stamped permit submission on its own. The Authority Having Jurisdiction (AHJ) and a licensed electrician must review and approve the final installation. All calculations reference Marine — ABYC E-11 (AC & DC Electrical Systems on Boats).

Document ID: PL-SAMPLE32-BOAT



Generated by PowerLab — a MarinePowerLab product · powerlab.marinepowerlab.com

1 — Executive Summary

Project: Sample 32 ft Sailboat — DC + AC Demo

Date: 2026-06-01

Document ID: PL-SAMPLE32-BOAT

Connected nameplate: 4,968 W · Daily energy: 3,451 Wh (288 Ah at 12 V) · Demand-factored design load: 5,043 W → 421 A at 12 V DC.

At a Glance

Battery bank	800 Ah at 12 V · 4 × 200Ah in parallel · LIFEP04 · 80% max DoD · 2-day autonomy budget · ≈ 96 kg
Solar array	6 × 200 W panels = 1,200 W · 125 A MPPT controller · ≈ 300 Ah/day at 4 peak sun hours
Inverter	5,000 W continuous · 4,335 W surge · 120 V single-phase output · surge driven by Watermaker pump
Load count	16 enabled · 10 continuous · 6 non-continuous · 11 DC · 5 AC
OCPDs / Conductors	4 overcurrent devices · 6 trunk conductors sized

Project Identifiers

Owner / Applicant:	Sample Owner (demonstration)
Installation type:	Sailboat — Vancouver Harbour, BC (sample location)
Nominal system voltage:	12 V DC
System architecture:	12 V DC bus + 120 V single-phase via 5,000 W inverter
Applicable code:	Marine — ABYC E-11 (AC & DC Electrical Systems on Boats)
Generated:	2026-06-01, 10:49 p.m. PDT

One-Line System Diagram (Preview)

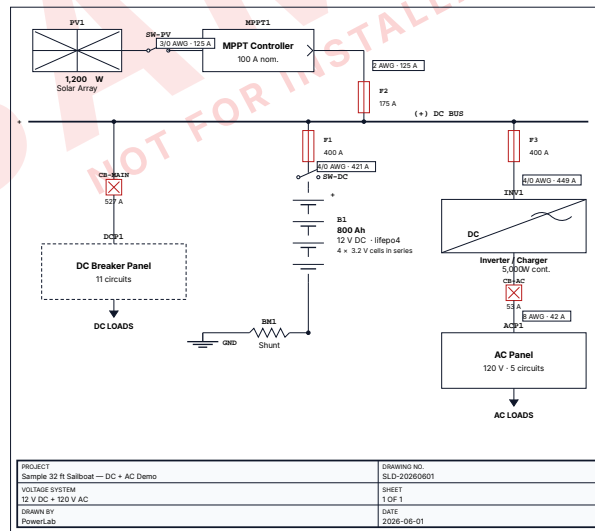

Overcurrent protection at every source (solar, battery) and at the panel main per ABYC E-11 §11.10 (Overcurrent Protection). Grounding and bonding per ABYC E-11 §11.16 (Bonding & Grounding). A full-page version of the diagram with annotated conductors and overcurrent ratings follows on the next page.



1.1 — Detailed Single-Line Schematic

Project: Sample 32 ft Sailboat — DC + AC Demo

Date: 2026-06-01

Document ID: PL-SAMPLE32-BOAT

Each conductor is labelled with its calculated gauge and the peak ampacity it carries; each overcurrent device is labelled with its rating. The schematic shows the canonical trunk runs (battery, solar, inverter DC + AC). Branch-circuit wiring inside the DC and AC load panels is the installer's responsibility and is documented on the conductor schedule that follows.

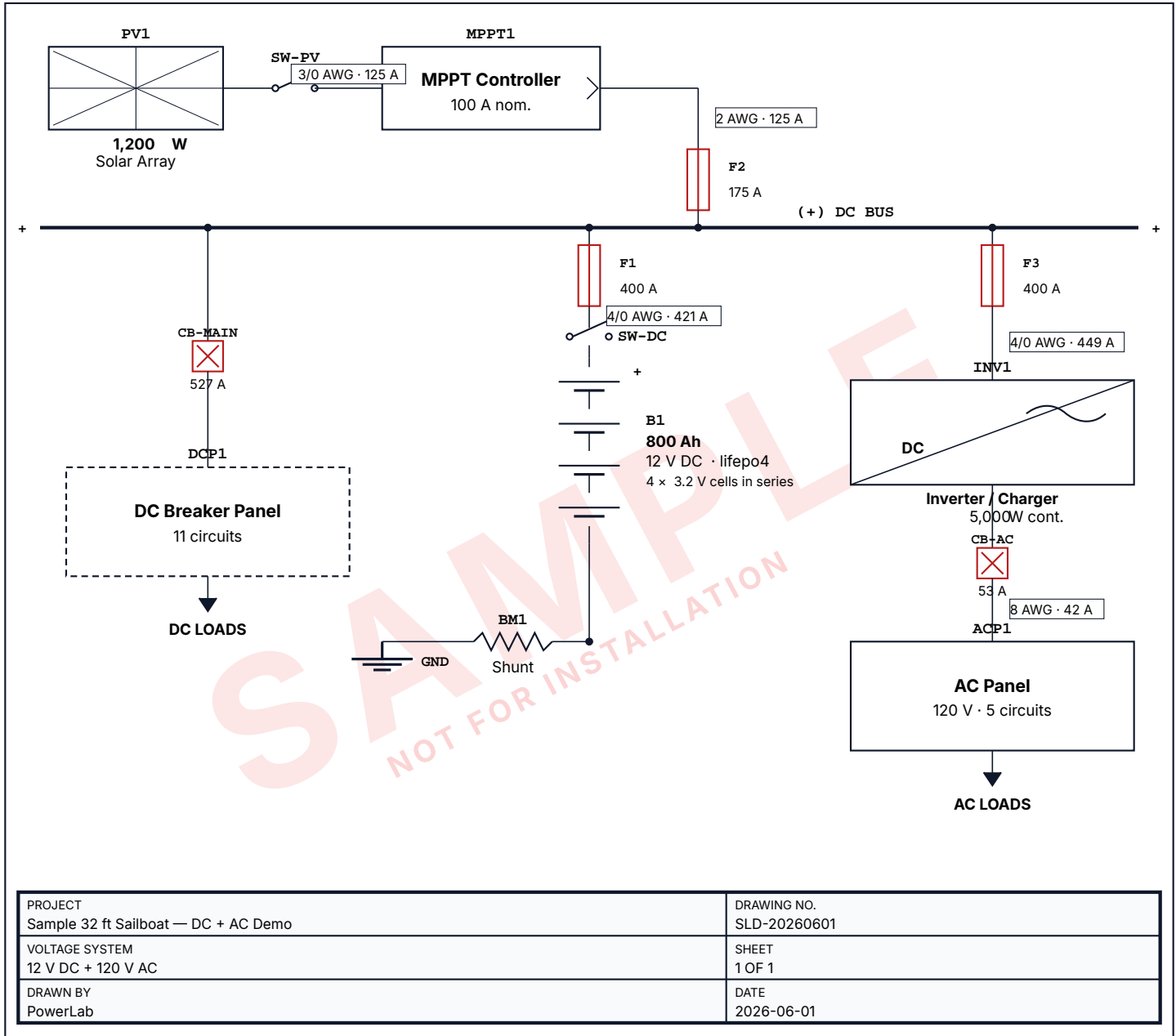

PROJECT Sample 32 ft Sailboat — DC + AC Demo	DRAWING NO. SLD-20260601
VOLTAGE SYSTEM 12 V DC + 120 V AC	SHEET 1 OF 1
DRAWN BY PowerLab	DATE 2026-06-01

Symbol legend

Drawn per IEC 60617 / ANSI Y32.2 / ABYC E-11 single-line conventions.

- Battery cell (long + / short -)
- Manual disconnect (open)
- PV array
- Fuse (IEC bisecting line)
- Chassis / earth bond
- Bus bar (heavy line)
- Circuit breaker (X disconnect)
- Inverter (DC | ~)
- Connection (●)

Conductor color code (Marine — ABYC)

ABYC E-11 §7 + Annex F

 DC positive (+)

 ABYC E-11 §7

 DC positive — alternative (yellow / red)

 High-current battery cables

 DC negative (-)

 Preferred since ABYC E-11 (2008)

 DC negative — legacy

 Permitted; new installs use yellow

 Bonding / safety ground

 ABYC E-11 §11.16

 AC hot (single-phase)

 AC hot — Leg 2 (split-phase)

 AC neutral

Notes: F1 = battery trunk fuse (DC-rated, Class T or MRBF, located within 7 in / 178 mm of the positive battery terminal per ABYC E-11 §11.10 and NEC 240.21(C)). F2 = solar charge-controller output fuse. F3 = inverter DC input fuse. CB-Main = main DC panel breaker. All overcurrent ratings are drawn from the conductor-schedule calculation shown on the OCPD & Conductor Schedule page; cross-reference for interrupt ratings (AIC).

SAMPLE
NOT FOR INSTALLATION



2 — Load Schedule

Continuous vs Non-Continuous (all enabled loads)

Load	Qty	W each	Hrs/day	Wh/day	AC/DC	Type
Bow + stern nav lights	2	6	6	72	DC	Continuous
Anchor light	1	4	12	48	DC	Continuous
Cabin LED lights	6	8	5	240	DC	Continuous
DC refrigerator (12V)	1	50	12	600	DC	Continuous
Chartplotter	1	18	6	108	DC	Continuous
VHF radio	1	6	8	48	DC	Continuous
AIS receiver	1	4	24	96	DC	Continuous
Cabin fan (12V)	2	18	4	144	DC	Continuous
Stereo + USB charging	1	30	4	120	DC	Continuous
Laptop charger	1	90	4	360	AC	Continuous
Bilge pump (auto)	1	60	0.5	30	DC	Non-cont.
Water pressure pump	1	50	0.5	25	DC	Non-cont.
Microwave (1100W)	1	1500	0.2	300	AC	Non-cont.
Induction cooktop (single burner)	1	1800	0.5	900	AC	Non-cont.
Coffee maker	1	900	0.2	180	AC	Non-cont.
Watermaker pump	1	360	0.5	180	AC	Non-cont.
Subtotals	16	4,968	—	3,451	—	—

AC vs DC split

DC nameplate total: 318 W (11 loads)

AC nameplate total: 4,650 W (5 loads)

Continuous loads (≥ 3 hr operation) multiplied by 125% per demand-factor rules; non-continuous taken at nameplate. Effective design load = $298 \text{ W} \times 1.25 + 4,670 \text{ W} = 5,043 \text{ W}$, equivalent to 421 A at 12 V DC. Reference: ABYC E-11 §11.10 (Overcurrent Protection).

2.1 — 24-Hour Load Profile (Indicative)

Stacked-area chart of energy use by category across a typical 24-hour day. The shape per category — lighting peaking evening, refrigeration flat, residential twin morning + evening peaks — is a heuristic informed by typical use; PowerLab does not collect time-of-use data per load. Use this chart to understand WHEN energy is consumed (e.g. inverter idle losses, daylight solar harvest overlap) and to inform inverter / battery surge headroom. Battery capacity sizing is driven by the Wh/day total on the Load Schedule, not the diurnal shape below.

24-Hour Load Profile — Sample 32 ft Sailboat — DC + AC Demo

Stacked-area chart of energy demand (Wh / h) by load category, computed from this project's enabled loads.

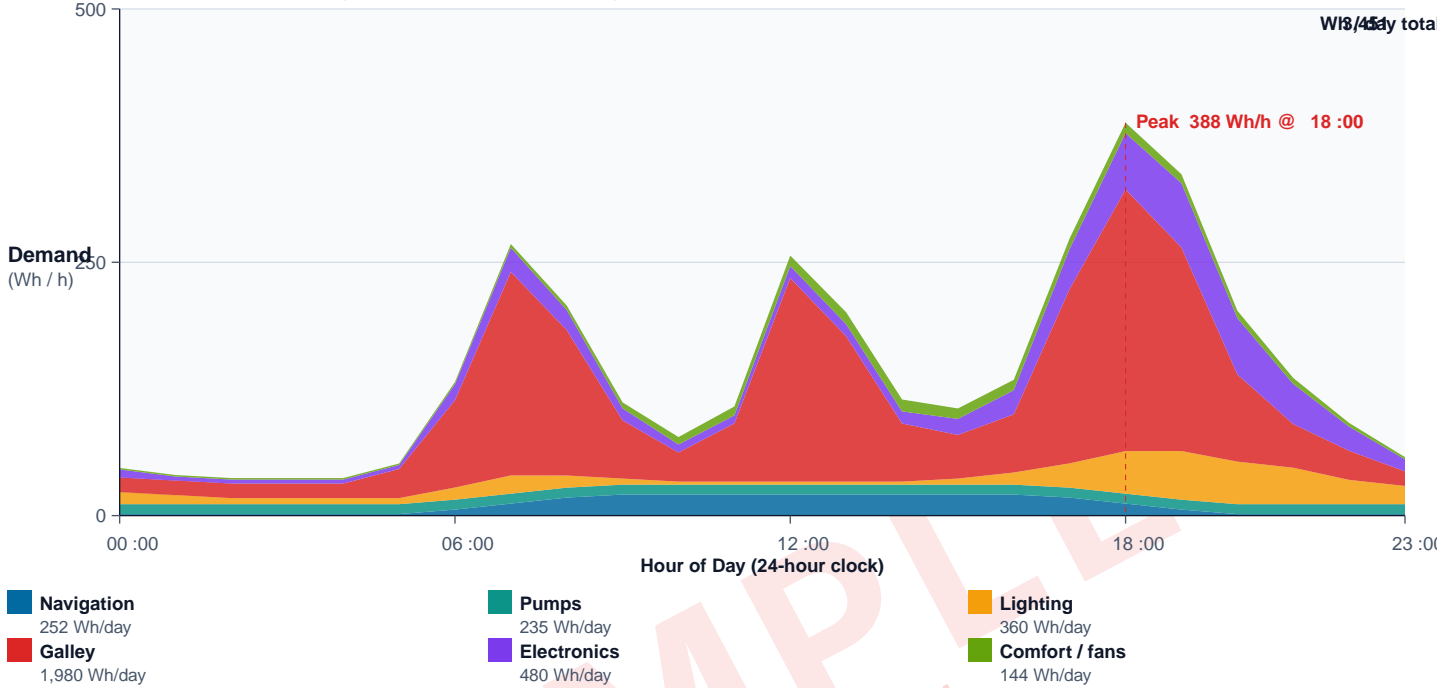

At-a-glance

Peak hour	18:00 · 388 Wh/h (32 A at 12 V DC equivalent)
Daily energy (chart total)	3,451 Wh — matches the Load Schedule subtotal within rounding.
Categories shown	Navigation, Pumps, Lighting, Galley, Electronics, Comfort / fans

Chart is illustrative — actual hour-by-hour load varies with crew schedule, weather, and seasonal use. AHJ submission and battery / inverter sizing calculations on the following pages reference the daily-Wh and demand-factored continuous load, not the heuristic profile above.

3 — Battery Bank Sizing

Inputs

Daily energy	$3,451 \text{ Wh} \div 12 \text{ V} = 288 \text{ Ah/day}$
Days of autonomy	2 days (worst-case run from a full bank with no charging input)
Battery chemistry	LiFePO4, max DoD 80%

Calculation

Required capacity = (daily Ah \times days of autonomy) \div max DoD
= $(288 \times 2) \div 0.80$
= 719 Ah
 \approx 800 Ah (rounded up to nearest standard bank size)
Usable capacity = 800 Ah \times 80% = 640 Ah

Recommendation

Bank configuration	4 \times 200Ah in parallel
Estimated weight	\approx 96 kg (212 lb) — verify mounting capacity
Estimated cost range	\$3,520 – \$5,720 (USD, batteries only — does not include cabling, BMS, mounting hardware)

Your daily consumption is 288Ah. With 2 days of autonomy, you need 575Ah of usable capacity. LiFePO4 (Lithium Iron Phosphate) batteries should only be discharged to 80% depth of discharge, so you need 719Ah of total capacity. We recommend a 800Ah bank (4 \times 200Ah in parallel), giving you 640Ah of usable capacity — enough for 2 days without any charging. Reference: ABYC E-10 + E-11 §11.4. Marine installations require ignition-protected cells and tinned battery cabling.

Battery Trunk Sizing

The battery trunk fuse (F1) is sized to protect the smallest conductor in the trunk against short-circuit current. With 421 A demand-factored peak draw, F1 = 527 A continuous-rated (peak \times 125%). Interrupt rating 20,000 A minimum at 12 V DC — confirm against the battery manufacturer's short-circuit current published spec.

SAMPLE
NOT FOR INSTALLATION

4 — Solar Array & MPPT

Inputs

Daily energy budget	3,451 Wh/day
Peak sun hours	4 h/day (site-specific average; verify NREL or PVWatts for the installation latitude)
System loss factor	75% delivered (after temperature, wiring, MPPT, soiling, and battery acceptance losses)

Calculation

Required PV watts = daily Wh ÷ (peak sun hours × loss factor)
= 3,451 ÷ (4 × 0.75)
= 1,198 W
≈ 1,200 W (6 × 200 W panels)
Daily charge = 1,200 W × 4 h × 0.75 ÷ 12 V ≈ 300 Ah/day

MPPT Charge Controller

Min controller rating	125 A (sized to PV array Isc × 125% per NEC 690.8)
Recommended type	MPPT recommended — higher efficiency at this array size
Estimated cost range	\$1,825 – \$4,875 USD (panels + controller, before mounting hardware)

Your daily consumption is 3451Wh. With 4 peak sun hours, a 75% system efficiency factor, and LiFePO4 (Lithium Iron Phosphate) round-trip efficiency of 96%, you need 1198W of solar panels. We recommend 6 × 200W panels (1200W total). This array will produce approximately 300Ah per day at 12V. You'll need a charge controller rated for at least 125A. MPPT recommended — higher efficiency at this array size. Reference: ABYC E-11 §11.4 (Solar Photovoltaic). Array conductors per ABYC E-11 §11.5 / §11.6 (Conductors); rapid-shutdown (NEC 690.12) required for residential rooftop installations.

SAMPLE
NOT FOR INSTALLATION

5 — Inverter Sizing

AC Load Schedule

Load	Qty	W each	Motor?	Essential?	Phase
Microwave (1100W)	1	1500	—	—	—
Induction cooktop (single burner)	1	1800	—	—	—
Coffee maker	1	900	—	—	—
Laptop charger	1	90	—	—	—
Watermaker pump	1	360	Yes	—	—

Calculation

AC nameplate sum = 4,650 W
Continuous running (with 70% diversity factor) = 3,255 W
+ 25% headroom for inverter heat de-rating = 4,069 W minimum continuous
+ Largest motor surge (Watermaker pump) = 1,080 W \approx 100 ms peak
Peak surge = 4,335 W
 \approx 5,000 W continuous inverter (rounded up to standard size)

Recommendation

Continuous rating	5,000 W (required 4,069 W)
Surge rating	\geq 4,335 W for 100 ms
Output topology	120 V single-phase pure-sine output, listed for AC subpanel feed
DC input efficiency	\geq 92% peak — battery-bank Wh draw is increased by \approx 7% for AC loads

Summed AC nameplate is 4,650 W. At a 70% diversity factor, continuous is 3,255 W. Adding 25% headroom yields 4,069 W continuous. The Watermaker pump motor adds a 200% starting surge (1,080 W for \sim 100 ms). Inverter peak efficiency assumed 93%. Rounded up to a standard 5,000 W inverter. Reference: ABYC E-11 §11.17 (Inverter / Charger / AC Output).

6 — Conductor Schedule

Circuit	Amps	Run (ft)	Wire	V-drop %	Insulation
Battery trunk → main bus	421	6*	4/0 AWG	2.1%	Tinned Cu, 105 °C
Solar array → MPPT controller	125	20*	3/0 AWG	2.6%	Tinned Cu, 105 °C
MPPT controller → battery	125	6*	2 AWG	1.9%	Tinned Cu, 105 °C
Battery → inverter DC input	449	5*	4/0 AWG	1.8%	Tinned Cu, 105 °C
Inverter AC output (120V)	42	8*	8 AWG	0.3%	Tinned Cu, 105 °C
AC mains feeder → load panel	42	15*	8 AWG	0.7%	Tinned Cu, 105 °C

Thermal margin (heat-dissipation transparency)

Each conductor's ampacity is derated for ambient temperature and conductor bundling before being checked against the continuous-load 125% requirement. The margin column shows headroom: orange = under 5% margin, red = below requirement (re-size). Per ABYC E-11 Table 7 (ambient) + Table 6 (bundle) + Table 8 (ampacity).

Circuit	Base A	Ambient ×	Bundle ×	Final A	Req A (×1.25)	Margin
Battery trunk → main bus	460	1.00	1.00	460	526	-66 A · -13%
Solar array → MPPT controller	395	1.00	1.00	395	156	+239 A · +153%
MPPT controller → battery	215	1.00	1.00	215	156	+59 A · +38%
Battery → inverter DC input	460	1.00	1.00	460	561	-101 A · -18%
Inverter AC output (120V)	55	1.00	1.00	55	53	+3 A · +5%
AC mains feeder → load panel	55	1.00	1.00	55	53	+3 A · +5%

* Lengths marked with an asterisk are typical-install defaults; the installer must verify actual run lengths on site and re-size if they exceed the default. Conductor ampacity per ABYC E-11 §11.5 / §11.6 (Conductors). Marine installations require tinned copper. Voltage-drop target ≤ 3% per ABYC E-11 §11.5 / §11.6 (Conductors). Every conductor protected by an OCPD sized to its ampacity. Base ampacity values reference ABYC E-11 Table 8 (105 °C tinned copper); ambient + bundle factors per the corresponding derate tables.

SAMPLE
NOT FOR INSTALLATION

7 — Overcurrent Protection Schedule (OCPD)

Device ID	Location	Rating (A)	Min AIC Type
F1	Battery positive, within 7" of terminal	400	20,000 DC-rated, Class T / MRBF
F2	Solar controller output	125	20,000 DC-rated breaker
CB-Main	DC main panel input	527	20,000 Main DC disconnect
F3	Inverter DC input fuse, within 7" of battery	561	20,000 DC-rated, Class T
CB-AC	AC main breaker, inverter output	53	10,000 AC main disconnect

All OCPDs must be DC-rated where shown with interrupt rating \geq the available short-circuit current at their node. Reference: ABYC E-11 §11.10 (Overcurrent Protection). Values shown are minimums — actual AIC depends on battery chemistry and bank size. Confirm with battery manufacturer's short-circuit rating.

SAMPLE
NOT FOR INSTALLATION

8 — Standards Citations & Conflicts

Where ABYC E-11 (marine) and NEC NFPA 70 (residential / off-grid) recommend the same approach, both are cited for credibility. Where they differ, the table below identifies the governing standard for this project — ABYC for marine vessels, NEC for cabin / RV / off-grid installations — and explains the choice. Inspectors and ABYC-cert installers should review this section before stamping.

Project standard policy

Project type	marine — governing standard for conflicts: ABYC E-11
Buyer-selected jurisdiction	Marine — ABYC E-11 (AC & DC Electrical Systems on Boats)

Conflict resolution table

Topic	ABYC citation	NEC citation	Governing
Conductor ampacity tables ★	ABYC E-11 §6 (Conductor Ampacity)	NEC §310.16 (Allowable Ampacities of Insulated Conductors)	ABYC
Marine installations use ABYC E-11 §6 because its base ampacity already assumes engine-room ambient (40–50 °C) and no bundle credit, which matches typical boat installs. NEC §310.16 free-air values would over-rate the conductor on a moving vessel.			
DC overcurrent device location ★	ABYC E-11 §11.10 (Overcurrent Protection — within 7 in / 40 in sheathed)	NEC Article 240 / §240.21 (Tap Rules — up to 10 ft sheathed)	ABYC
Marine projects MUST use ABYC E-11 §11.10: the battery-positive fuse sits within 7 inches of the terminal (or 40 inches if the conductor is in conduit). The short-distance rule limits arc-flash energy on the unfused leg in a vibration-prone, salt-spray environment.			
Grounding & bonding point topology ★	ABYC E-11 §11.16 (Bonding & Grounding Systems)	NEC Article 250 (Grounding & Bonding)	ABYC
Marine bonding ties DC negative, AC safety ground, engine block, and underwater metals at a single bonding bus. A galvanic isolator on the AC shore-power ground prevents stray-current corrosion. ABYC §11.16 is unambiguous about this topology — NEC §250 does not address vessel-specific bonding.			
AC vs DC distribution panel separation ★	ABYC E-11 §11.4 (Panel Construction & Separation)	NEC Article 404 (Switches) / §312.7 (Switchgear Enclosures)	ABYC
Marine installs require physical separation of AC and DC distribution per ABYC §11.4. Salt-water environment + bilge moisture + crew touching wet metal makes a cross-fault between AC and DC disproportionately dangerous on a vessel. Separate panels (or barriered combo panels) eliminate the cross-bridge path.			
Battery installation in / near living space ★	ABYC E-11 §11.18 (Battery Installation, Ventilation, Compartment)	NEC Article 480 (Stationary Storage Batteries)	ABYC
Marine battery boxes follow ABYC §11.18: ventilation to outside or non-living space, restraint against pitch & roll, sealed-top boxes for flooded chemistries, and no fuel-system penetrations through the battery compartment.			

★ Rows highlighted with a star are directly applicable to this project shape. Where the table marks "ABYC" or "NEC" as governing, the conflicting clause from the other standard is informational — useful when an out-of-jurisdiction inspector reviews the document. The AHJ retains final authority on which clauses apply locally.



9 — Grounding & Bonding

Required Bonds

Battery negative bus	Bonded to system DC ground bar via copper bonding strap, sized to peak DC fault current.
System DC ground bar	Bonded to vessel bonding system + galvanic isolator on shore-power AC ground.
PV array frame	Equipment-grounded via continuous bonding jumper from each module frame to the array racking and back to the system ground bar (NEC 690.43 / 690.45).
AC equipment ground	Inverter chassis bonded to AC subpanel ground bus; neutral-ground bond at the inverter when configured as an SDS, or at the main service when configured as a transfer switch — never both (NEC 250.30).
Galvanic isolator	Required on AC shore-power ground per ABYC E-11 §11.18 to prevent stray-current corrosion. Isolator must carry the full shore-power AC current rating with low impedance to AC fault current.

Grounding electrode and bonding strap dimensions per ABYC E-11 §11.16 (Bonding & Grounding). Where multiple systems share a structure, the grounding electrode conductor is sized to the largest service. Marine bonding requires #8 AWG tinned copper minimum to underwater metallic components.

Code References

Solar / PV:	ABYC E-11 §11.4 (Solar Photovoltaic)
Battery / ESS:	ABYC E-10 + E-11 §11.4
Overcurrent:	ABYC E-11 §11.10 (Overcurrent Protection)
Conductors:	ABYC E-11 §11.5 / §11.6 (Conductors)
Grounding:	ABYC E-11 §11.16 (Bonding & Grounding)
AC inverter / load calc:	ABYC E-11 §11.17 (Inverter / Charger / AC Output)

SAMPLE
NOT FOR INSTALLATION

10 — Marine Specifics: Corrosion, Bonding, Stray Current

Marine installations face two failure modes residential systems do not: galvanic corrosion of submerged metal pairs, and stray current driven by AC ground or DC leakage. Both are addressed by bonding all metal hardware to a single common ground and by sacrificial anodes that corrode preferentially. The schematic and tables below summarise the requirements per ABYC E-2 (cathodic protection) and ABYC E-11 §11.16 (bonding) — confirm against the vessel's haul-out anode log before stamping.

Bonding System Map

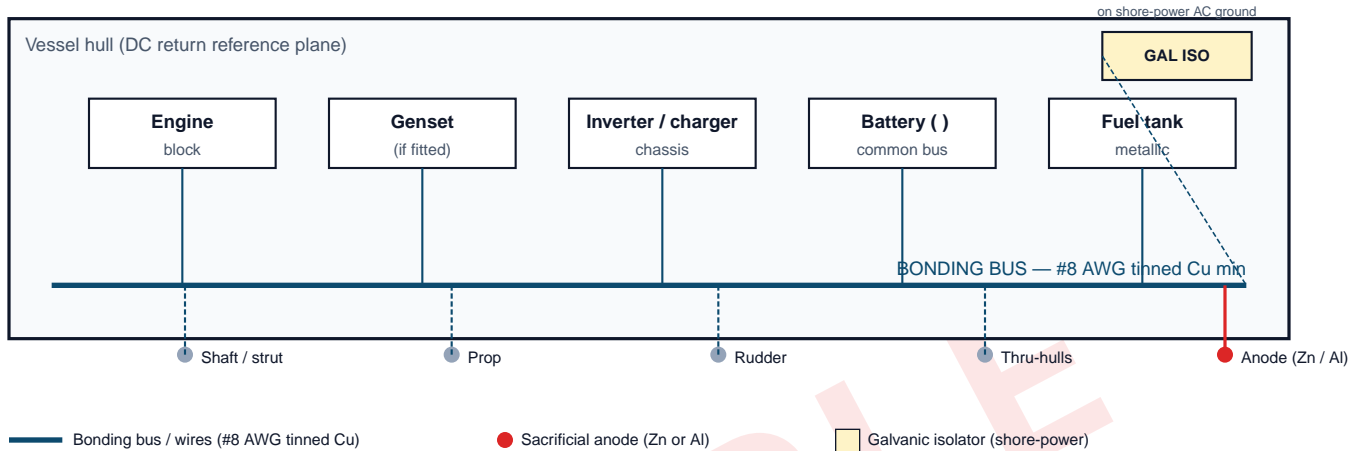

All metallic hardware below the waterline plus engine block, generator chassis, inverter / charger chassis, fuel tank, and metallic through-hull fittings must connect to the same DC bonding bus. Sacrificial anodes (zinc in salt; aluminum for brackish; magnesium for fresh water) are bonded to the bus so they corrode FIRST. Galvanic isolator on the AC shore-power ground breaks DC ground loops to shore without losing AC fault-clearing path. ABYC E-11 §11.16 minimum bonding conductor: #8 AWG tinned copper, terminated with crimp lugs and heat-shrink.

Galvanic Series (anodic → cathodic, in seawater)

Metal / alloy	V vs Ag/AgCl	Role
Magnesium	-1.60 to -1.63	Sacrificial
Zinc	-0.98 to -1.03	Sacrificial
Aluminum (galvanic-alloy)	-1.05 to -1.15	Sacrificial
Aluminum alloys (5052/6061)	-0.70 to -0.90	At risk
Mild / galvanised steel	-0.60 to -0.71	At risk
Cast iron	-0.55 to -0.65	At risk
Stainless 304 (active)	-0.40 to -0.50	At risk
Lead	-0.25 to -0.30	At risk
Manganese / silicon bronze	-0.27 to -0.30	At risk
Copper / brass	-0.30 to -0.36	At risk
Stainless 316 (passive)	-0.05 to -0.10	Cathodic (protected)
Silver	-0.00 to -0.05	Cathodic (protected)
Graphite / carbon fibre	+0.20 to +0.30	Cathodic (protected)

Two metals more than ~0.20 V apart in this series form a galvanic cell when wetted by an electrolyte (salt or brackish water). The more anodic metal corrodes preferentially. Bond both to a sacrificial anode that is more anodic still, and inspect the anode at every haul-out — replace at 50% mass loss per ABYC E-2 §3.4.

10.1 — Dissimilar-Metal Pairings & Mitigation

Pairing	Risk	Mitigation
Aluminum hull + bronze prop / shaft fitting	HIGH	Sacrificial Al-galvanic anode on shaft + hull; isolate fitting from hull where possible.
Steel hull + bronze through-hull / strainer	HIGH	Sacrificial zinc on hull near fitting; tinned bonding wire to common ground.
Bronze prop + 304 SS shaft	HIGH	Replace 304 with 316 SS; bond shaft to engine + anode via brush or wire.
Aluminum mast + stainless rigging	MED	Insulate mast step from hull; rinse rigging with fresh water; replace damaged anodised coating.
Steel keel bolts + bronze through-hulls	MED	Bond keel + through-hulls to common DC ground; check anode wear quarterly.
Bronze prop + bronze shaft	LOW	Same-alloy match — anode wear is normal; replace at 50% mass.
Tinned-copper conductors + tinned-brass terminals	LOW	No further mitigation — this IS the marine-grade pairing.
Galvanised fasteners + 316 SS hardware	MED	Use 316 SS fasteners; if galvanised present, bond to anode and inspect at haul-out.

HIGH-risk pairs require both an anode bonded to the affected hardware AND quarterly visual inspection of the bonded items for corrosion at the bonding crimp, the anode connection, and any below-waterline fitting. MED-risk pairs tolerate annual inspection. LOW-risk pairs are the marine-grade default and need only the standard haul-out inspection cycle.

Stray-Current Protection

DC negative ↔ AC ground	Bonded at a SINGLE point — typically the inverter's chassis ground lug. Multiple bonding points create a parallel return path through seawater that drives stray current and accelerates corrosion (ABYC E-11 §11.16.4).
Galvanic isolator	Required on the AC shore-power green-wire ground. Breaks DC potential between vessel and dock without breaking the AC fault-clearing path. Must be rated for the full shore-power AC current (typically 30 A or 50 A) and certified to ABYC A-28 / UL 1102 (ABYC E-11 §11.5.7).
Isolation transformer	Alternative to galvanic isolator — fully isolates vessel AC from shore. Pricier and heavier; preferred for steel hulls and vessels in marinas with chronic stray-current issues. Bonded per ABYC E-11 §11.5.6.
Reverse-polarity / leakage	ELCI (Equipment Leakage Circuit Interrupter) trip ≤ 30 mA at the shore-power inlet protects against ground-fault leakage that would otherwise drive stray current through bonded hardware (ABYC E-11 §11.5.5).

Conductor Material — Tinned Copper Mandate

ABYC E-11 §11.5.1 requires CLASS B or finer stranded copper, tinned, for ALL conductors in a marine installation — including bonding wire, battery cables, DC distribution, and AC branch circuits. Untinned copper oxidises at the strand interfaces in marine humidity, increasing resistance and creating heat at crimp terminations. Brass terminals are forbidden in DC current paths (zincification under load); use tinned-copper or marine-grade nickel-plated copper terminals only.

11 — Maintenance Schedule

Operations checklist sized to this project. Each row carries an interval, the action, and a citation to the standard or manufacturer recommendation that drives it. Liveboards and fleet operators can use this as the basis for a vessel-specific maintenance log.

Monthly (3 items)		
Item	Action	Reference
Battery state-of-charge check	Read SoC % at the BMS / shunt monitor; record in vessel log. Flag if resting voltage diverges from SoC reading.	ABYC E-11 §11.18
Bilge pump operation (marine)	Lift float switch; confirm pump runs and discharges within 30 seconds. Check fuse holder for corrosion.	ABYC H-22
Inverter idle-current draw	With AC loads off, read DC input current at the inverter shunt. A creep above 1 A may indicate a failing transformer or capacitor.	Mfr. service manual
Quarterly (5 items)		
Item	Action	Reference
Battery terminal cleaning + torque	Disconnect, wire-brush terminal posts, apply NO-OX-ID compound, retorque to manufacturer spec (typically 6-12 ft-lb for LFP M8).	ABYC E-11 §11.18 / Mfr.
Cable inspection at chafe points	Trace every #4 AWG and larger run; inspect at clamps, bulkheads, and engine-room penetrations. Replace abraded jacket immediately.	ABYC E-11 §11.5
MPPT controller + panel cleaning	Wash array glass with mild soap; check panel mounting hardware for backout. Brush MPPT controller heat sink with soft brush; vacuum vent slots.	NEC 690.43 / Mfr.
Inverter cooling-fan inspection	Verify the inverter's temperature-controlled fan spins under load. Vacuum air-intake screen. Listen for bearing rumble.	Mfr. service manual
BMS balance-cycle verification (lithium)	Run a full charge to 100% and confirm cell-voltage spread at top of charge is within 50 mV. A wider spread indicates imbalance — schedule equalization.	Mfr. BMS guide
Semi-annual (4 items)		
Item	Action	Reference
Overcurrent device function test	Visually inspect every fuse + breaker for discoloration. Trip-test resettable breakers. Replace any fuse showing oxide on contact surfaces.	ABYC E-11 §11.10 / NEC §240
Grounding bond continuity	Use a low-resistance ohmmeter ($\leq 0.1 \Omega$ target) between battery negative and ground bus, and between ground bus and through-hull / electrode.	ABYC E-11 §11.16 / NEC §250
Motor-load bearing check	Listen at each motor (pumps, fans, compressors) for bearing growl. Vibration > 5 mm/s peak indicates impending failure — schedule service.	Mfr. service manual
Galvanic isolator continuity (marine)	Bypass-test isolator with multimeter; verify forward voltage drop ≤ 1.4 V when AC fault current flows. Replace if fails-open.	ABYC E-11 §11.18

Annual (5 items)		
Item	Action	Reference
Battery capacity test	Discharge bank from 100% to 20% SoC at C/5 rate; record actual Ah delivered. Replace bank when delivered Ah falls below 80% of nameplate.	Mfr. + ABYC E-11 §11.18
Anode replacement (marine)	Replace shaft, hull, and engine block anodes when more than 50% wasted. Verify bonding to vessel ground bus is continuous after install.	ABYC E-2 / E-11 §11.16
BMS firmware update	Check BMS / inverter manufacturer for firmware updates. Apply via vendor app; record old + new version in the vessel log.	Mfr. release notes
Solar array IV-curve scan	Use a multimeter at MPPT input under full sun to record array Voc + Isc. Compare to nameplate; > 10% drop suggests soiling, shading, or panel degradation.	NEC 690.4 / Mfr.
AC subpanel thermal scan	Under typical load, IR-scan every breaker + lug. Hot spots > 20 °C above ambient indicate loose connections — re-torque and re-scan.	NEC §110.14 / NFPA 70B

Biennial (3 items)		
Item	Action	Reference
Compartment ventilation check	Verify battery compartment ventilation path is clear and rated for chemistry (open vent for FLA / sealed enclosure for LFP). No fuel lines penetrate.	ABYC E-11 §11.18 / NEC §480
Conductor megger test	Megger insulation between conductor and ground at 500 V for low-voltage systems. > 1 MΩ pass; lower indicates insulation degradation.	NFPA 70B / ABYC E-11
Inverter capacitor inspection	Open inverter case; visually inspect electrolytic capacitors for bulging or leakage. Replace any capacitors showing physical deformation.	Mfr. service bulletin

Schedule reflects 20 project-specific items. Manufacturer-supplied service manuals supersede generic intervals where they conflict. Severe-service environments (offshore, dusty desert, high-cycling fleet) typically halve the intervals shown.

SAMPLE
NOT FOR INSTALLATION



12 — Compliance Disclosure & Approvals

This document is an engineering-input report generated from project data the customer entered into PowerLab. All sizing recommendations follow Marine — ABYC E-11 (AC & DC Electrical Systems on Boats). The recommendations are starting values for a permit submission — actual installation must be reviewed and approved by a licensed electrician (ABYC certified installer for marine systems; state/provincial-licensed electrician for residential / off-grid systems) and stamped by the local Authority Having Jurisdiction (AHJ) before energizing.

PowerLab does not warrant fitness for any specific installation, does not assume liability for installation defects, and does not represent itself as an electrical contractor unless explicitly stated elsewhere. Local AHJ approval may impose additional requirements (e.g., listed-product requirements, AFCI / GFCI placement, working clearances) not exhaustively captured here.

Approvals

Designer of record (owner or qualified person)

Name: _____

Signature: _____ Date: _____

Licensed electrician review

Name: _____

License # / ABYC Cert #: _____ State / Province: _____

Signature: _____ Date: _____

AHJ stamp / permit number

(For permit office use)

Document ID: PL-SAMPLE32-BOAT · Generated: 2026-06-01, 10:49 p.m. PDT · Prepared by PowerLab (powerlab.marinepowerlab.com)

